

Model No. SGC-3-250X2XT

THE COPYRIGHT IN THESE DRAWINGS AND PLANS REMAINS VESTED IN SMART ENERGY SYSTEMS. THE DESIGNS AND PLANS MAY NOT BE USED WHOLLY OR IN PART WITHOUT THE WRITTEN PERMISSION OF SMART ENERGY SYSTEMS

SYSTEM SPECIFICATIONS

- TOTAL mj/hr RATING 1500 mj/hr
- HOT & COLD PLUMBING EACH TANK
- 50mm CONNECTIONS AS STANDARD
- SYSTEM PRODUCES AT 65°C
- 7240 LITRES FIRST HOUR PEAK
- ELECTRICAL CONECTION FOR WIRING PROVIDED WITH PLANT ELECTRICAL BOX INC ISOLATION SWITCH 240V 50hz NOMINAL
- 864 watts

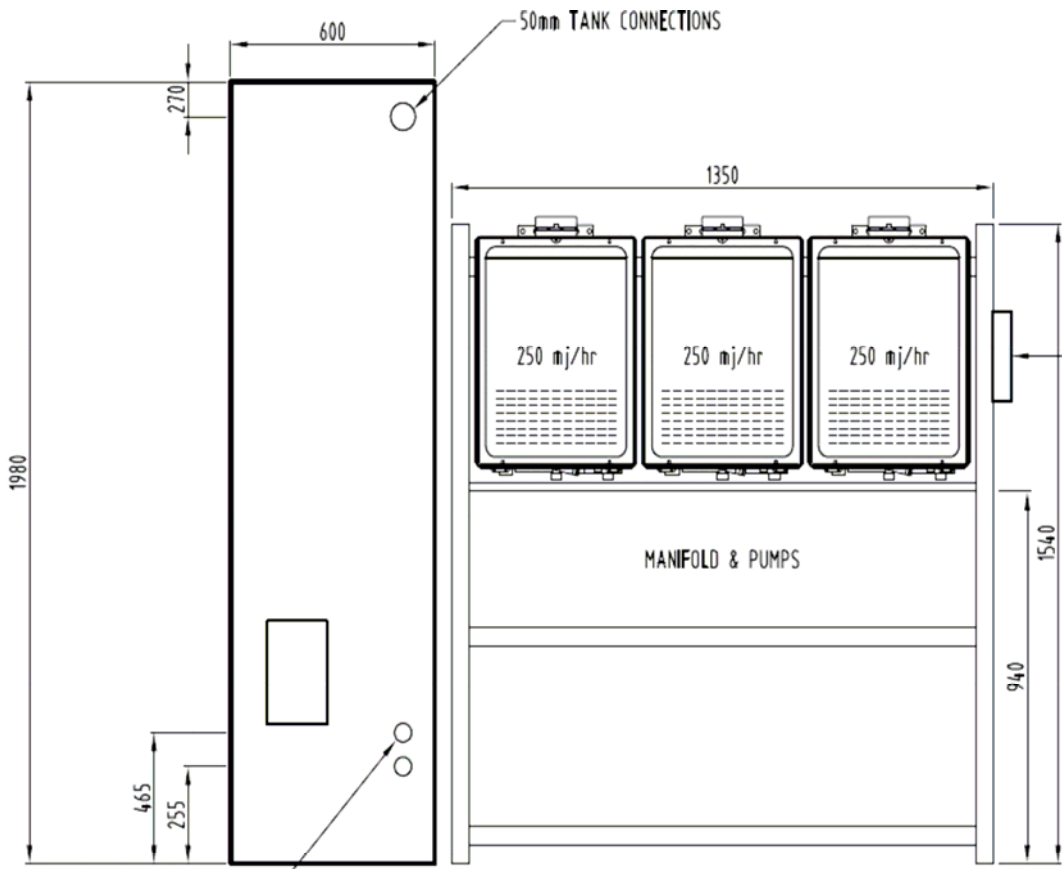
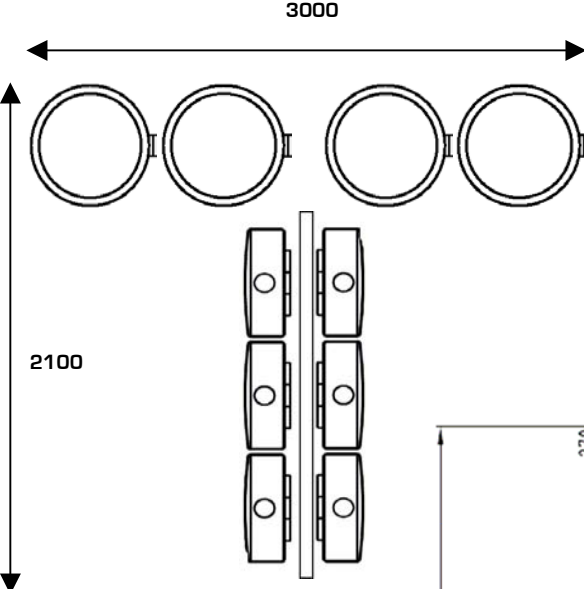

SECONDARY HOT WATER RETURN (50mm BSP FEMALE)

SMART ENERGY SYSTEMS
 COMMERCIAL HOT WATER SYSTEMS
 HEAD OFFICE
 47 Johnston Street
 SOUTHPORT QLD 4215
 Ph: 1300 303 486
 Fax: (07) 5571 0881
 sales@smartenergysystems.com.au
 www.smartenergysystems.com.au

Model No. SGC-3-250X2XT