

THE COPYRIGHT IN THESE DRAWINGS AND PLANS REMAINS VESTED IN SMART ENERGY SYSTEMS. THE DESIGNS AND PLANS MAY NOT BE USED WHOLLY OR IN PART WITHOUT THE WRITTEN PERMISSION OF SMART ENERGY SYSTEMS

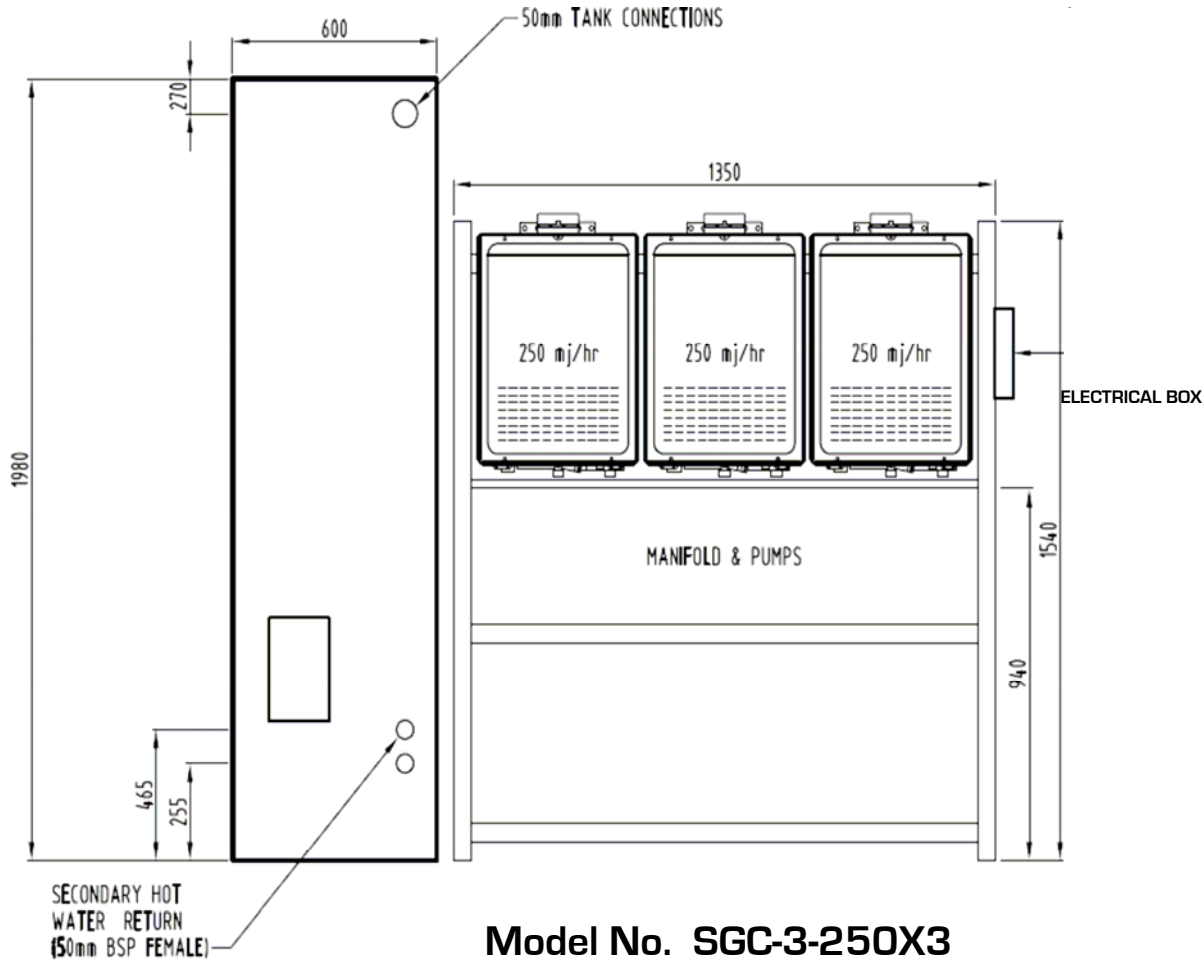

**Model No. SGC-3-250X3**

## SYSTEM SPECIFICATIONS

TOTAL mj/hr RATING 2250 mj/hr

HOT & COLD PLUMBING EACH TANK

50mm CONNECTIONS AS STANDARD

SYSTEM PRODUCES AT 65°C  
9830 LITRES FIRST HOUR PEAK

ELECTRICAL CONNECTION FOR WIRING PROVIDED WITH PLANT  
ELECTRICAL BOX INC ISOLATION SWITCH 240V 50hz NOMINAL  
1296 watts

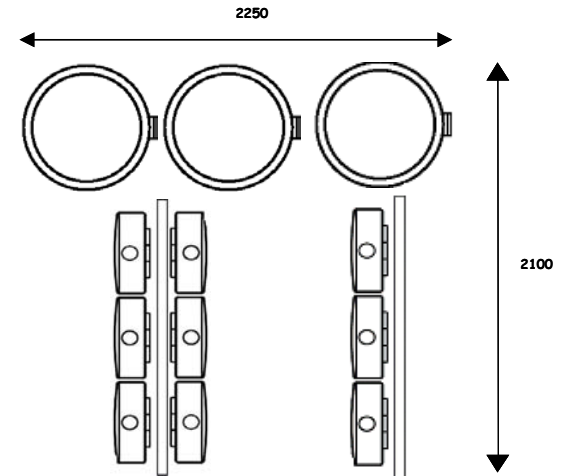

**SMART ENERGY SYSTEMS**

COMMERCIAL HOT WATER SYSTEMS

HEAD OFFICE  
47 Johnston Street  
SOUTHPORT QLD 4215

Ph: 1300 303 486  
Fax: (07) 5571 0881  
sales@smartenergysystems.com.au  
www.smartenergysystems.com.au

**Model No. SGC-3-250X3**

MODEL NO: SGC-3-250X3