

THE COPYRIGHT IN THESE DRAWINGS AND PLANS REMAINS VESTED IN SMART ENERGY SYSTEMS. THE DESIGNS AND PLANS MAY NOT BE USED WHOLLY OR IN PART WITHOUT THE WRITTEN PERMISSION OF SMART ENERGY SYSTEMS

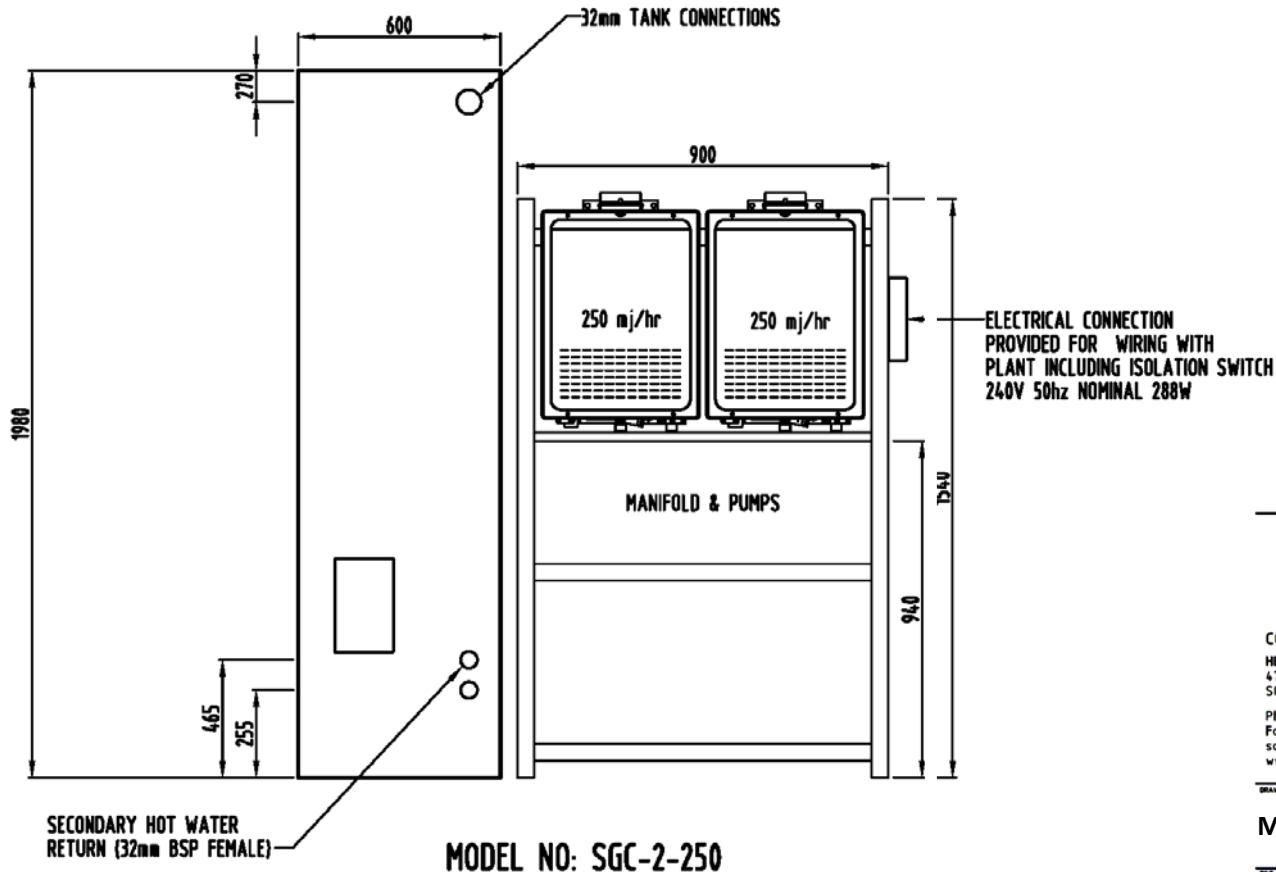
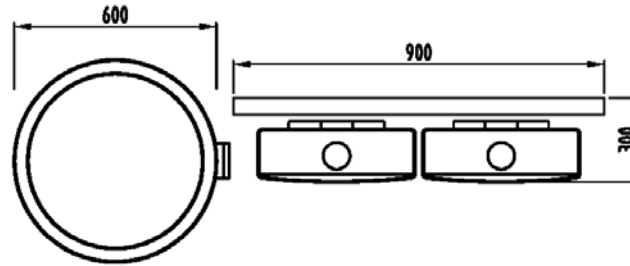

## SYSTEM SPECIFICATIONS

TOTAL mj/hr RATING 500 mj/hr

HOT & COLD PLUMBING EACH TANK

32mm CONNECTIONS AS STANDARD

SYSTEM PRODUCES AT 65°C  
2290 LITRES FIRST HOUR PEAK

ELECTRICAL CONNECTION AS INDICATED ON DRAWING

**SMART ENERGY SYSTEMS**

COMMERCIAL HOT WATER SYSTEMS

HEAD OFFICE  
47 Johnston Street  
SOUTHPORT QLD 4215

Ph: 1300 303 486  
Fax: (07) 5571 0881  
sales@smartenergysystems.com.au  
www.smartenergysystems.com.au

DRAWING

Model No. SGC-2-250

FILE SGC-3-250 DRAWN R.T.W. SCALE R.T.S.